



# booty kicker®

An innovation powered by Savvier Fitness®

## Use and Assembly Instructions

Video instructions can be found at [www.BootyKicker.com/Instructions](http://www.BootyKicker.com/Instructions)  
 Congratulations on receipt of your Fitness Barre. The innovative patent pending design will provide you with great Barre fitness workouts that will kick your booty, tighten your abs and tone your entire body.

### CAUTION! READ ALL INFORMATION BEFORE USE. SERIOUS INJURY OR FATALITY MAY OCCUR

- The Booty Kicker® is not a toy. Keep out of reach of children.
- Always check with your physician before starting this or any exercise program.
- Do not use the Booty Kicker® for anything other than its intended exercise purpose. Use only as shown, illustrated and intended.
- Do not attempt any type of gymnastic movements on the Booty Kicker®.
- Always inspect the Booty Kicker® before every use for loose screws, nuts or damage. Tighten any screws or nuts prior to use. If you find any cracks or damage, then discontinue use immediately.
- Only use the Booty Kicker® on a clean level surface making sure you have adequate clearance around the Booty Kicker® for performing the exercises.
- When using the Booty Kicker®, only engage your hands, arms, legs, or feet with the wooden barre. The metal uprights and base legs are not intended to be used as gripping or exercise surfaces.
- Similarly, when using any type of resistance band with the Booty Kicker®, engage the band only with the wooden barre. Do not allow bands to contact sharp objects. Be sure to inspect any resistance bands before use and discontinue use if any signs of nicks or tears.
- When first attempting any exercise, use caution while determining your physical limitations. When performing any exercise involving pushing or pulling forces on the barre, use caution to assure such forces do not create an instability causing either you or the barre to tip over. Placing hands (or in the case of a resistance band) towards the middle of the wooden barre increases stability.
- Placing weights in the weight racks increases the Booty Kicker® stability for performing certain pushing/pulling exercises. Removing weights during exercises reduces the unit stability.
- Be sure to wear appropriate exercise clothing.
- Always properly store the Booty Kicker® indoors after use. The Booty Kicker® could pose a hazard to children and pets, and should not be left unattended. Store out of reach of children when not in use.
- Use caution when folding, as hinges may pose pinch points for fingers, hands, feet and toes. When the Booty Kicker® is in the folded position, always secure base legs and uprights together with the two Velcro straps. Weights should be removed from weight racks when moving / transporting the Booty Kicker®.

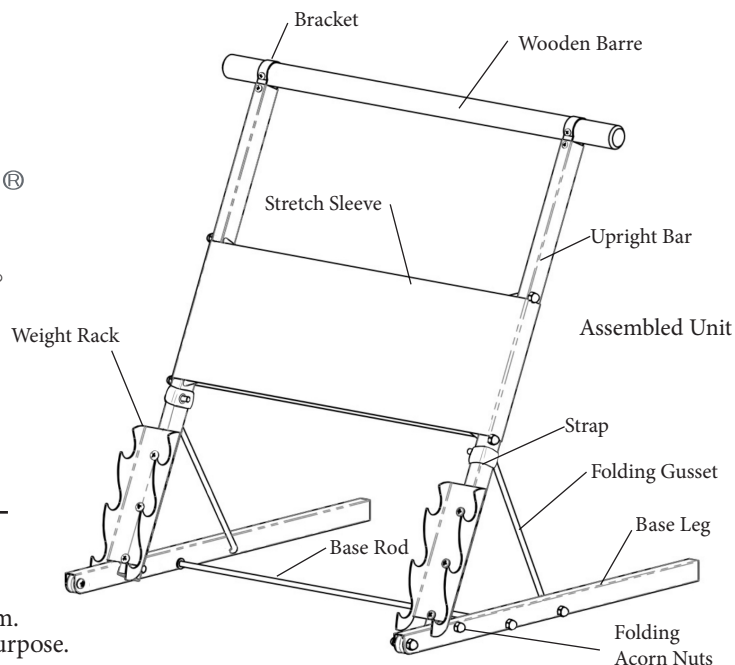

### Assembly Steps:

Assemble on a hard, flat, level surface (not carpet or rug). Carefully unpack and familiarize yourself with each component, assembly, hardware and tools. Remove the Base Rod and two Cross Rods shipped inside the Upright Bar and the Leg Assemblies.

#### Step 1

- Place the two Leg Assemblies flat on the floor with the **Acorn Nuts facing outward**.
- With the Leg Assembly still in the folded position. Place the two identical Cross Rods into the holes of the Upright Bars, as shown in Fig.1. Secure with four Acorn Nuts, forming an X between the Upright Bars. (Hand tighten only) Note the Top Cross Rod overlaps on top of other Cross Rod as shown
- Place the Base Rod between the Leg Assemblies and into the holes shown in Fig1, Secure with two Acorn Nuts. (Hand tighten only)
- Place each Folding Gusset into the holes on the Base Bar, as shown in Fig.1. Secure with two Acorn Nuts. Important, Acorn nuts face outward. (Hand tighten only)

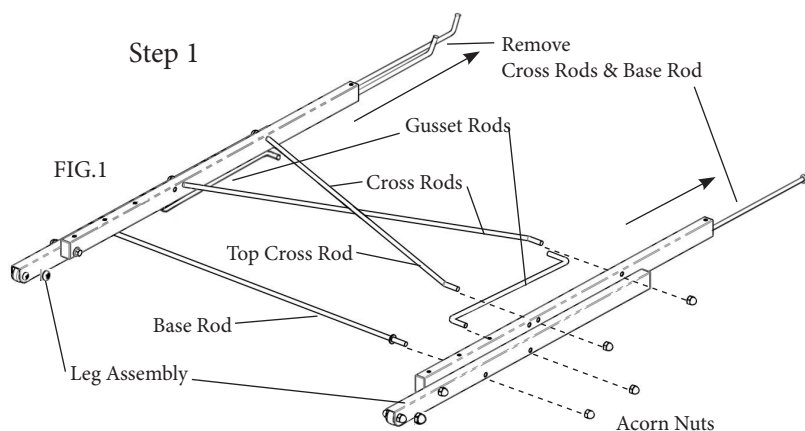

#### Step 2

- Holding the Base Leg in place, rotate the Upright Bars to approximate position. As shown in Fig.2
- While holding the Upright Tube in place, Rotate a Folding Gusset upward. Holding the end of the Folding Gusset, gently flex the end outward. Aligning the open end of the Folding Gusset and hole on the Upright Bar. Gently release the Folding Gusset completely through the Upright Bar hole. As shown in Fig.2. Repeat on the other side of the assembly.
- Place the Straps onto the Gusset Rods. While holding the unit in place, gently pull outward on a Gusset Rod and rotate to place the first hole of the Strap onto the Gusset Rod. Important. Assemble the Strap with the hook or scratchy side of the Velcro facing upward. As shown in Fig.2. Do not wrap the Strap yet.

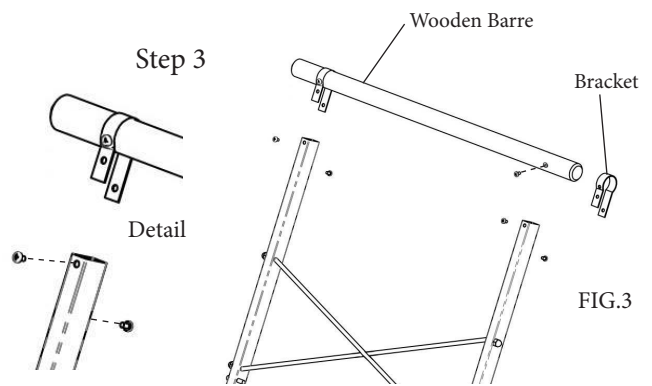
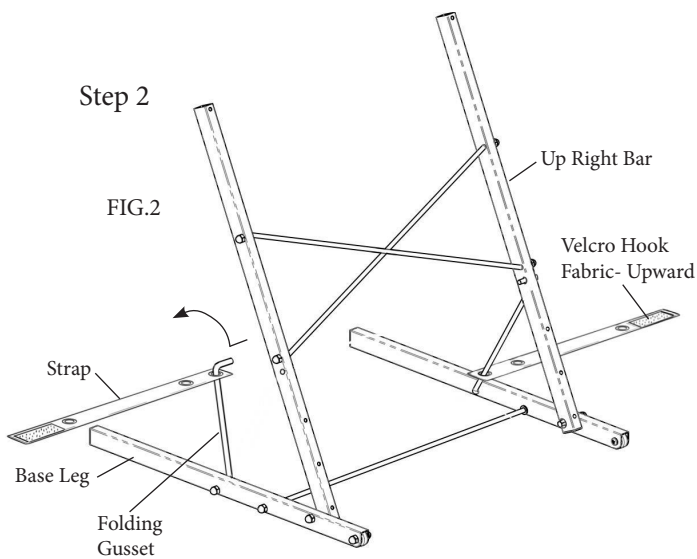

### Step 3

- Place the Brackets, in the same orientation, onto the Wooden Ballet Barre, as shown in Fig.3. Place an Allen head screw through the Bracket and into the threaded insert on the Wooden Barre. Repeat on the opposite side. (Hand tighten only)
- Place the Wooden Barre with assembled Brackets into the open top of the Upright Bar. **Noting the different hole locations.** Gently squeezing the ends of the Brackets, place the long end of the Bracket into the Upright Tube on both sides, first. And then insert the shorter ends of the Brackets to align with all four holes of the Upright Bar. As shown in Fig3. Insert four Allen head screws into the holes. As shown in Fig.3 Detail. (Hand tighten only)

### Step 4

- Be sure your Booty Kicker® is on a flat level surface. Placing light downward force on the Wooden Barre, check that all four corners of the assembly are sitting flat on the floor. If the unit does not sit flat or rocks, then while standing at the Barre, carefully apply downward and side to side force until the unit is resting flat.
- Using the Tool provided, partially tighten the eight Acorn Nuts of the Cross Rods, Base Rod and Folding Gussets. Alternating sides as you tighten.
- Wrap the Strap two times around the Upright Bar, engaging the two remaining holes of the Strap with the open end of the Gusset Rod and secure the Velcro. Repeat for the Strap on the opposite side.
- Check again the assembly is sitting flat. If not flat, then slightly loosen the Acorn Nuts and repeat the downward, side to side adjustment process. Once the unit is sitting flat, tighten the six Allen head screws around the Brackets. Then fully tighten the six Acorn Nuts of the Cross Rods and Base Rod. To allow folding, gently tighten the Gusset Acorn Nuts. Confirm unit is sitting flat and if needed repeat the loosen / adjustment / tighten process.
- Place the Stretch Sleeve onto the Full Assembly, one side at a time. Align the Sleeve between the Cross Bar Acorn Nuts with the seam of the Sleeve between the Cross Bar Acorn Nuts and the seam of the Sleeve at the Upright Bar. As shown in Fig.5

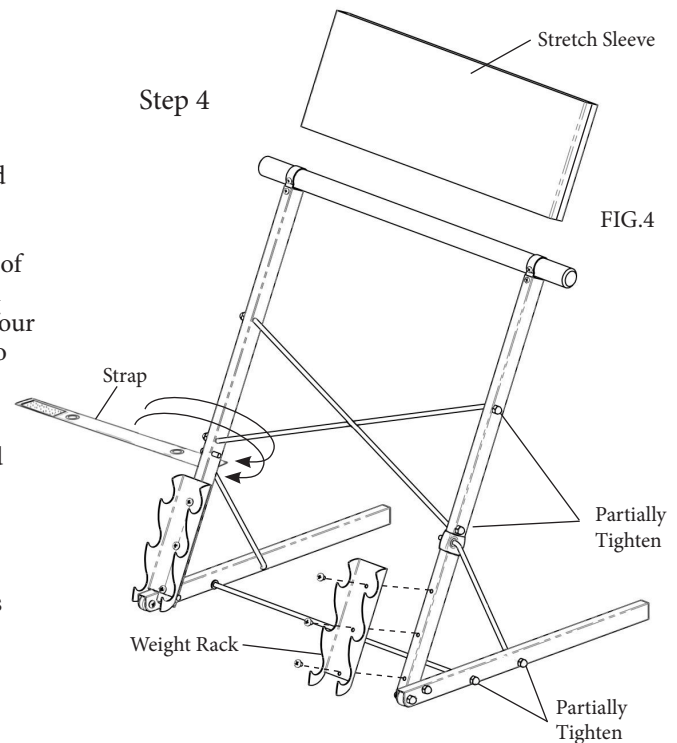

### Step 5

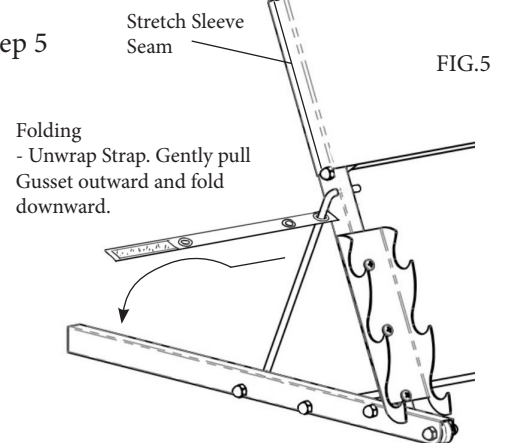

### Step 5

#### Weight Racks

- Assemble the optional identical Weight Racks with the weight openings facing upward. Align the three holes of the Weight Stack to the Upright Bar, as shown in Fig.4. and insert three Allen screws per side.
- Assure that the Weight Rack part is clear of the Base Leg. Tighten each Allen screw
- Place weights onto each Weight Rack, placing the heaviest dumbbell at the bottom.

### Folding

- Unwrap the Strap from each side of the fully assembled Barre
- While holding the Barre securely, gently pull outward on a Gusset and fold the Gusset downward. Repeat on the other side and fold the unit downward to meet the Base Bar. As shown in Fig.6
- On each side, wrap the strap around both bars and secure the Velcro
- The folded Barre Assembly may be lifted and rolled. Weights should be removed prior to moving or transporting the Barre Assembly.

